



HF-REGULATOR II Analog pro TL-D

HF-R 158 TL-D EII 220-240V 50/60Hz

Vysokofrekvenční elektronický předřadník pro regulaci stmívání s použitím analogového protokolu (1–10 V) pro zářivky TL-D

Údaje o produktu

• Obecné informace

Interface	1-10V
Application code	EII
Rated Lamptype	TL-D
Rated Number of Lamps	1 piece
Rated Ballast-Lamp Power	58
Síťové napětí	220-240 V
Síťová frekvence	50/60 Hz
Housing	L 360x30x21
Index energetické efektivity	A1
Životnost - 10% selhání	50000 hr
Ignition Method	Programmed Start

• Provozní údaje

Automatic restart	Yes
Ignition time	0.2 (max) s
Operating frequency	45 (min), 105 (max) kHz
Mains voltage safety (AC)	-10%/+10%
Mains voltage performance (AC)	-8%/+6%
Inrush current Peak	27 (max) A
Inrush current Width	0.25 ms
Earth leakage current	0.5 (max) mA
Power losses gear	6.3 W
Regulating level power	1%-100%
PowerFactor 100% output power	0.97 -
Battery voltage lamp ignition	196 V

Battery voltage running lamps	154-276
Overvoltage protection 320Vac	48 hr
Overvoltage protection 350Vac	2 hr
Control input protection	Yes (Basic insulation)
Max. počet na jistič	28 x
Stable lamp operation temp.	- [Not specified]
Crestfactor	1.7 (max) -
Hum and Noise level	Inaudible
Total Harmonic Distortion EUR	6 %

• Schéma zapojení

Conn.type input terminals	WAGO 251 universal connector [Suitable for both automatic wiring (ALF and ADS) and manual wiring]
Conn.type output terminals	WAGO 251 universal connector [Suitable for both automatic wiring (ALF and ADS) and manual wiring]
Conn.type ctrl input terminals	WAGO 251 universal connector [Suitable for both automatic wiring (ALF and ADS) and manual wiring]
Striplength	8.0-9.0 mm
Dual fixture Master/Slave	Not applicable [Master/Slave oper. not applicable]
Wcs Control input terminals	0.50-1.00 mm2
Wcs Input terminals	0.50-1.00 mm2
Wcs Output terminals	0.50-1.00 mm2
Wcs auto insertion (ALF/ADS)	0.5 mm2

PHILIPS

HF-REGULATOR II Analog pro TL-D

• Teplotní údaje

T-ignition	0 (min), 50 (max) C
T-ambient	-20 (min), 50 (max) C
T-storage	-25 (min), 80 (max) C

• Rozměry produktu

Length A1	360 mm
Fixing Hole Distance	350 mm
Length A2	
Width B1	30 mm
Height C1	22 mm
Fixing Hole Diameter D1	4.2 mm

• Aplikační charakteristika

EMI 9kHz .. 30 MHz	EN 55015
EMI 30 MHz .. 1000MHz	EN 55022 level B [Level = Class]
Safety Standard	IEC 61347-2-3
Performance Standard	IEC 60929
Quality Standard	ISO 9000:2000
Environmental Standard	ISO 14001
Harmonic current emissions	IEC 61000-3-2

EMC Immunity	IEC 61547
Vibrations	IEC 68-2-6 Fc
Bumps	IEC 68-2-29 Eb
Humidity	EN 61347-2-3 clause 11
Approval marks	ENEC / VDE-EMV
CE marking	Yes
Temperature marking	110 [Yes]
Emergency standard	IEC 60598-2-22

• Produktové informace

Objednávkové číslo	910172 30
Kód produktu	871150091017230
Název produktu	HF-R 158 TL-D EII 220-240V 50/60Hz
Název objednávaného produktu N	HF-R 158 TL-D EII 220-240V 50/60Hz
Pocet kusu v balení N	1
Balící množství	12
Pocet balení v transportním balení	12
EAN produktu	8711500910172
EAN transportního balení	8711500910189
eop_12nc	913700609466
Hmotnost produktu	0.270 kg

Rozměrové výkresy

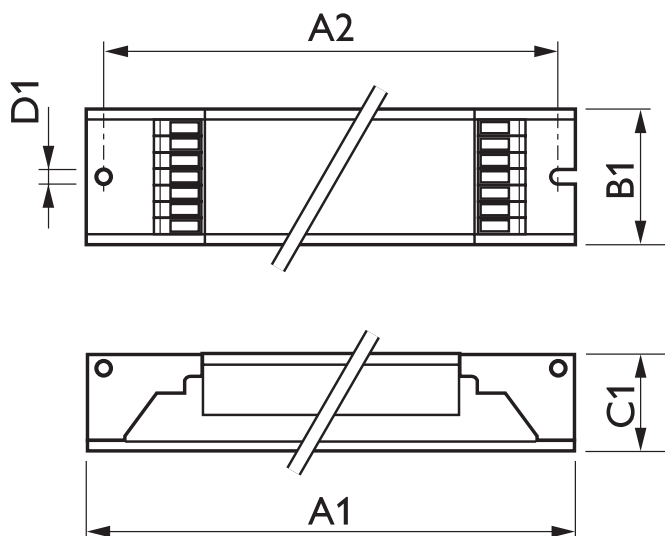

HF-R 158 TL-D EII 220-240V 50/60Hz

Product	A1 (Norm)	A2 (Norm)	B1 (Norm)	C1 (Norm)	D1 (Norm)
HF-R 158 TL-D EII 220-240V 50/60Hz	360	350	30	22	4.2

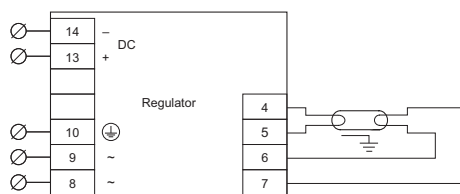

HF-R 1 lamp TL5/PL-L/TL-D



© 2014 Koninklijke Philips N.V. (Royal Philips)
Všechna práva vyhrazena

Změna specifikací bez upozornění. Ochranné známky jsou vlastnictvím Koninklijke Philips N.V. (Royal Philips) nebo jejich příslušných majitelů.

www.philips.com/lighting

2014, Březen 26
Změna údajů vyhrazena